



## Explosion Proof Light

We are committed to delivering high-quality industrial lighting fixtures designed, tested and certified for use in hazardous locations and adverse environment conditions.

Our explosion proof light can be used even under the harshest indoor and outdoor conditions. If safety, labor reduction, quality and reliability are your priorities, this product will be your best option.

**Explosion Proof**

Gas & dust proof  
Zone 1, 2 & zone 21, 22  
High bright 150lm/w



**IECE<sub>x</sub>**



**II 2G Ex db mb IIB T4 Gb  
II 2D Ex tb IIIC T(95°C) Db**

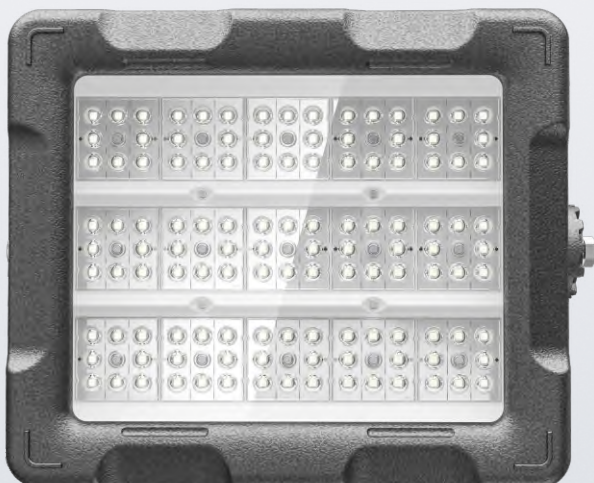

**150LM/W**

Driver: Meanwell  
LED: Cree

## Various optics:

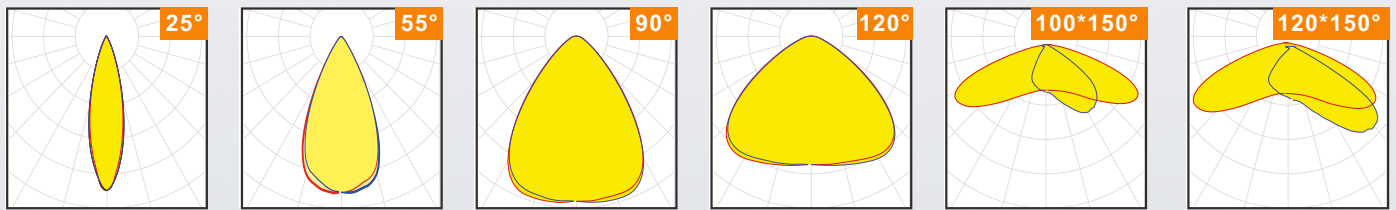

Precise Angle Rotation

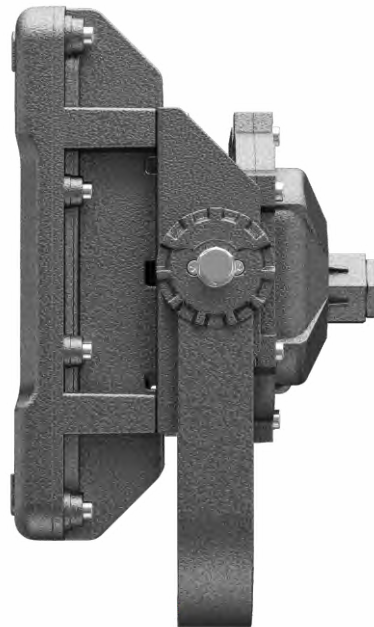

IP66 Waterproof  
6KV/10KV Surge Protection  
AkzoNobel coating, best corrosion proof

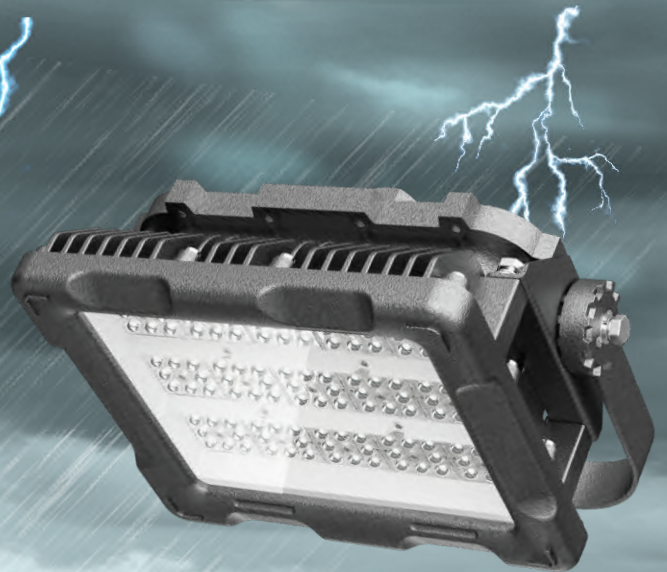



Chemical industry  
 Oil and natural gas extraction  
 Petrol station  
 Offshore  
 Marine sector



Tank vehicle  
 Shipyard  
 Power plant  
 Refinery  
 Rescue service  
 Aviation



Sugar refinery  
 Grain and feed industry  
 Fertiliser industry  
 Flour milling  
 Pharmaceutical industry  
 Waste treatment plant  
 Timber industry



# Application

Zone 1 Zone 2  
 Zone 21 Zone 22

Applied to oil fields, oil refineries, offshore oil platform, power plants, gas stations, oil tanks, wharf, tunnel, pumping station, substation, the military base, etc. Zone I and Zone II Hazardous Locations, Zone 20, Zone 21, Zone 22 and II A, IIB, IIC explosive gas atmosphere.



## Features

- Housing: Pure Aluminum
- Thermal Conductivity: 226 W/m·K
- Led: Cree 3030
- CRI: Ra>70
- SDCM: <6
- Power Factor: >0.95
- THD: <15
- Driver: Meanwell
- Driver Efficiency: >93%
- Protection: OTP, OCP, OVP, SCP
- Surge Protection: 6KV
- Waterproof: IP66
- Impact Test: IK08
- Electrical: 100-277V, 50/60Hz
- Operating Temperature: -40~60°C
- TM21: L90B10>50,000H
- Lifetime: 50,000H



**Ex** II 2G Ex db mb IIB T4 Gb  
II 2D Ex tb IIIC T1 (95°C) Db

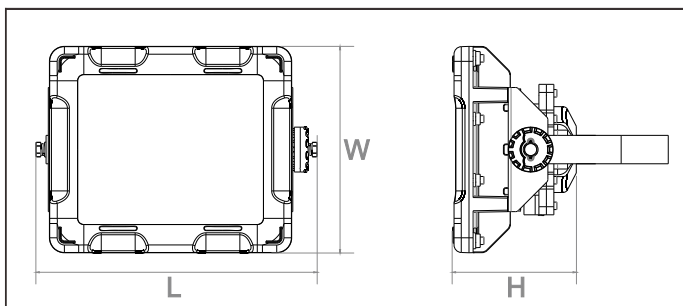

## Functions

ZigBee · DMX · DALI · 0/1~10V

## Optical options:

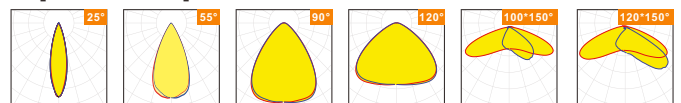

Model	Watt	Voltage	Lumen	CRI	IP	Dimension
EX025AE1H-CM	25W	100~277V	3750LM	>70	IP66	374*276*171
EX050AE1H-CM	50W	100~277V	7500LM	>70	IP66	374*276*171
EX070AE1H-CM	70W	100~277V	10500LM	>70	IP66	374*276*171
EX100AE1H-CM	100W	100~277V	15000LM	>70	IP66	374*276*171
EX150AE1H-CM	150W	100~277V	21000LM	>70	IP66	374*276*171
EX200AE1H-CM	200W	100~277V	28000LM	>70	IP66	374*276*171

# Packing

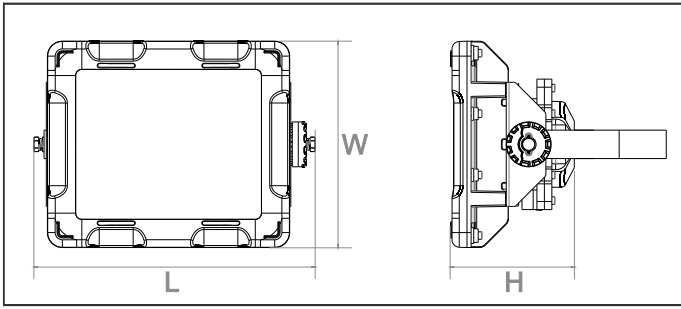

## Luminaire

Model	Dimension (mm)	Outer Carton(mm)			QTY / Outer CTN	Luminaire	
		L	W	H		NW(kg)	GW(kg)
EX025AE1H-CM	374*276*171	435	415	270	1	9.70	10.50
EX050AE1H-CM	374*276*171	435	415	270	1	9.70	10.50
EX070AE1H-CM	374*276*171	435	415	270	1	9.70	10.50
EX100AE1H-CM	374*276*171	435	415	270	1	9.70	10.50
EX150AE1H-CM	374*276*171	435	415	270	1	9.70	10.50
EX200AE1H-CM	374*276*171	435	415	270	1	9.70	10.50